

**Class 300 • Union Bonnet • Non-Rising Stem • SS Seats • Thrd. Ends**

**Gate Valve Figure B-147**

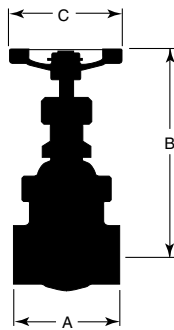
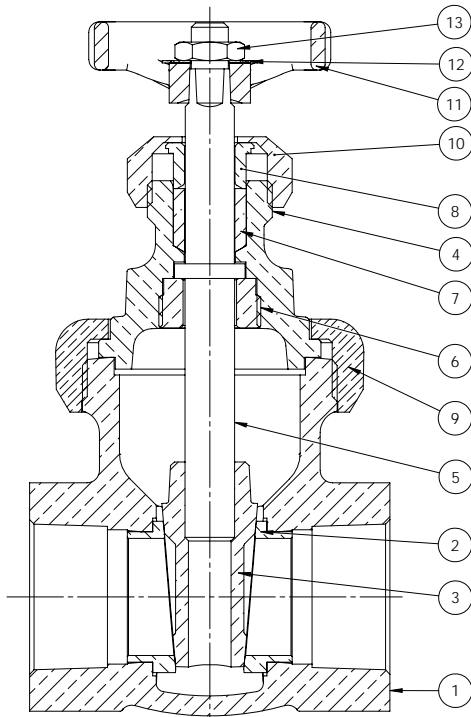

**Materials of Construction**

No.	Description	Material	ASTM Spec.
1	Body	Bronze	B-61 C92200
2	Disc	Bronze	B-61 C92200
3	Body Seat Ring	Stainless Steel	A-276 Type 410
4	Bonnet	Bronze	B-61 C92200
5	Stem	Bronze	B-371 C69400
6	Stem Retaining Nut	Brass	B-16 H02
7	Packing	Graphite (Asbestos Free)	
8	Gland	Brass	B-16 H02
9	Union Bonnet Ring	Bronze	B-61 C92200
10	Packing Nut	Brass	B-16 H02
11	Handwheel	Ductile Iron	
12	ID Plate	Aluminum	
13	Lock Nut	Steel Cadmium	

**NOTE:**

The addition of the letter "K" at the end of the figure number designates valves assembled & tested in the USA. Materials of Construction & Dimensions are the same.

**Industry Standards**

Complies with MSS SP-80 Type 1

See Page 6 for Pressure-Temperature Ratings

**Dimensions and Weights**

Inches (millimeters) - Pounds (kilograms)

Valve Size	Dimensions			Wt.
	B	C	A	
¼	3.46	2.25	2.03	0.81
	(88)	(57)	(52)	(0.37)
⅜	3.46	2.25	2.13	0.84
	(88)	(57)	(54)	(0.38)
½	3.85	2.75	2.44	1.32
	(98)	(70)	(62)	(0.60)
¾	4.38	2.75	2.61	1.83
	(111)	(70)	(66)	(0.83)
1	4.89	2.75	3.06	2.95
	(124)	(70)	(78)	(1.34)
1 ¼	5.88	4.00	3.35	4.44
	(149)	(102)	(85)	(2.02)
1 ½	6.66	4.00	3.69	5.65
	(169)	(102)	(94)	(2.57)
2	7.51	4.00	3.96	9.61
	(191)	(102)	(101)	(4.37)